

**iVDR**  
**- Outline of Hardware**  
**Specification -**  
**(EX type)**

**iVDR Consortium**

**Version 1.31**  
**Jul. 2011**

## Conditions of publication

This document presents an outline of “iVDR – Hardware Specification – [EX type] version 1.10, Oct. 2009.

### ■ Attention

This document presents only the outline specification. If you manufacture iVDR product, please join “iVDR Consortium” and manufacture it based on the official iVDR Specification.

### ■ Notes

Please refer to the above mentioned standard documents for the items indicated as “abbreviation” in sentences.

### ■ Publisher

iVDR Consortium

### ■ Inquiry

iVDR Consortium

[ <http://www.ivdr.org/> ]

#### **iVDR Consortium Secretariat:**

Located in I-O Data Device, Inc.

9<sup>th</sup> FL., North Wing, Akihabara UDX Bldg.,

4-14-1 Sotokanda, Chiyoda-ku, Tokyo, 101-0021, Japan

Phone/Fax: +81-3-6687-1570 E-mail: [info@ivdr.org](mailto:info@ivdr.org)

■ **Revision Description**

Ver.	Date	Change	Description of the change
1.00	Aug. 2008	Newly created	-
1.10	Sep. 2009	Change name	iVDR Xtreme → iVDR EX iVDR Hard Disk Drive Consortium → iVDR Consortium
1.20	Jan. 2010	Revised up	Revised up based on "iVDR Hardware Specification [EX type] version 1.10, Oct. 2009.
1.30	Oct. 2010	Revised up	Change iVDR Consortium Secretariat Location Revised up the reference version of Interface Specification
1.31	Jul. 2011	Added	Attention was added in "Conditions of publication"

# Contents

<b>1</b>	<b>General</b> .....	<b>1</b>
1.1	Scope.....	1
1.2	Reference .....	2
1.3	New world brought by iVDR [Informative] .....	3
<b>2</b>	<b>Hardware specifications</b> .....	<b>4</b>
2.1	Device specifications.....	4
2.2	Mechanical dimensions.....	6
2.2.1	External view .....	6
2.2.2	Outer dimensions .....	7
2.2.3	Weight.....	7
<b>3</b>	<b>Interface specifications</b> .....	<b>8</b>
3.1	Command and interface register descriptions .....	8
3.2	Physical and Electrical characteristics .....	8
<b>4</b>	<b>Connector specifications</b> .....	<b>8</b>
4.1	General specification.....	8
4.1.1	Configuration specification .....	8
4.1.2	Contact material and surface plating [Informative] .....	10
4.1.3	Labeling on the connector housing [Informative].....	10
4.2	Signal assignment for connector.....	11
<b>5</b>	<b>Detailed mechanical specifications</b> .....	<b>14</b>
5.1	Overall detailed diagram .....	14
5.2	Mechanical characteristics .....	18
5.2.1	Outer dimensions and Datum (X, Y, Z) .....	18
5.2.2	Guide rail.....	18
5.2.3	Eject area .....	18
5.2.4	Clamp area.....	18
5.2.5	Gaps for lock system.....	18
5.2.6	Connector position .....	19
<b>A</b>	<b>Specification of the iVDR device shockproof test [Normative]</b> .....	<b>20</b>
A.1	Test procedure.....	20
A.2	Test standard.....	20
A.3	Shock measurement [informative].....	20
A.4	Measurement tool of shockproof test .....	20
<b>B</b>	<b>Supplementary explanation related to the specification of the iVDR interface [Informative]</b> .....	<b>21</b>
B.1	Power ID Assignment.....	21
B.2	I/F ID Assignment .....	21
B.3	An example of system recognition by ID pin .....	21
<b>C</b>	<b>Receptacle Connector specification [Normative]</b> .....	<b>22</b>
C.1	Configuration specification .....	22

C.2	Contact material and surface plating [Informative] .....	23
C.3	Signal assignment for connector .....	23
<b>D</b>	<b>Connecting condition of connector [Informative].....</b>	<b>24</b>
D.1	Misalignment tolerance on a relative position of the connector.....	24
D.2	Fully-mated dimension .....	24
<b>E</b>	<b>Test specification of connector [Normative].....</b>	<b>24</b>
E.1	Test content and standard .....	24
E.2	Test procedure [Informative] .....	24
<b>F</b>	<b>Optional area [Informative].....</b>	<b>25</b>
F.1	Insertion direction mark area and label area .....	25
<b>G</b>	<b>Capacity of iVDR device [Informative].....</b>	<b>25</b>
G.1	Value of LBA count of iVDR device.....	25
<b>H</b>	<b>Example of Case with rounding edge [Informative] .....</b>	<b>26</b>

## 1 General

### 1.1 Scope

The iVDR device is portable data handling equipment with an interface connector. An example iVDR device is shown in Fig. 1.1.

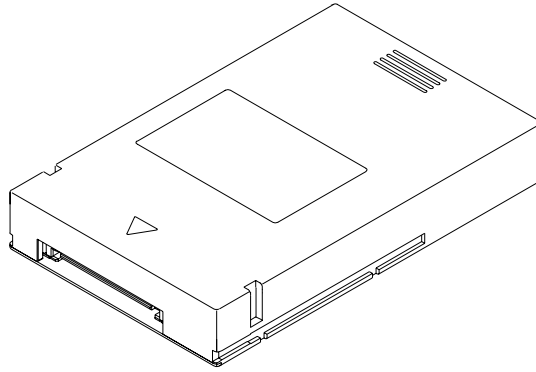

Fig. 1.1 External view of example iVDR device

This specification describes requirements for the iVDR device, including the dimensional characteristics, durability of the case, connectors and pins' assignment with ID setting.

## 1.2 Reference

- 1) iVDR 2010  
Interface specification (ATA) 2.10 (iVDR-IF-ATA)
- 2) iVDR Hard Disk Drive 2008  
Interface specification (USB) 0.9 (iVDR-IF-USB)
- 3) Serial ATA Interface Organization  
Serial ATA Revision 2.6, February 15, 2007 (Serial-ATA)
- 4) USB Implements Forum, Inc.  
Universal Serial Bus Specification, Revision 2.0, April 27, 2000 (USB-2.0)
- 5) MIL-STD-810C  
Test Method Standard for Environmental Engineering Considerations and Laboratory Tests
- 6) ANSI/EIA-364-20B-1999 (EIA364-20B)  
Withstanding Voltage Test Procedure for Electrical Connectors, Sockets and Coaxial Contacts
- 7) ANSI/EIA-364-21C-2000 (EIA364-21C)  
Insulation Resistance Test Procedure for Electrical Connectors, Sockets, and Coaxial Contacts
- 8) ANSI/EIA-364-23B-2000 (EIA364-23B)  
Low Level Contact Resistance Test Procedure for Electrical Connectors and Sockets
- 9) MIL-STD-202  
Test Methods for Electronic and Electrical Component Parts
- 10) MIL-F-14256E  
FLUX, SOLDERING, LIQUID (ROSIN BASE)
- 11) QQ-S-571E  
Solder; Tin Alloy, Tin-Lead Alloy, and Lead Alloy.
- 12) ANSI INCITS 340 2002  
Information Technology – AT Attachment with Packet Interface – 6 (ATA-6)
- 13) ANSI INCITS 340 2005  
Information Technology – AT Attachment with Packet Interface – 7 Volume 1 (ATA-7/V1)
- 14) The International Disk Drive Equipment and Materials Association  
LBA1-02: LBA Standard [Approved Standards of LBA Standards] (IDEMA/LBA1-02)

### **1.3 New world brought by iVDR [Informative]**

Abbreviation

## 2 Hardware specifications

### 2.1 Device specifications

#### (1) Power supply specifications

Table 2.1.1 Supply voltage specifications

NO	Item	Specification
1	Power	+5V±5 %
2	Ripple Noise	100 mVp-p Max (Frequency: DC to 1MHz)

Table 2.1.2 Supply current specifications

Item	Specification
	+5V input
Incident peak current	2 A Max
Maximum duration time of peak current	3 sec Max

#### (2) Environment specifications

Table 2.2.1 Operating environmental specifications

NO	Item	Specification
1	Temperature	5 °C to 50 °C
2	Relative humidity	8 % to 90 %
3	Wet bulb temperature	29.4 °C Max
4	Temperature gradient	20 °C/h Max
5	Atmospheric pressure	714 hPa to 1050 hPa
6	Vibration	9.8 m/sec <sup>2</sup> Max. at 5-500Hz 1octave / minute of swept sine wave

Note) Atmospheric pressure equivalents to the altitude of -300m to 3048m.

Table 2.2.2 Non-operating (Storage) environmental specifications

NO	Item	Specification
1	Temperature	-40 °C to 65 °C
2	Relative humidity	5 % to 95 %
3	Wet bulb temperature	40 °C Max
4	Temperature gradient	20 °C/h Max
5	Atmospheric pressure	282 hPa to 1050 hPa

Note) Atmospheric pressure equivalents to the altitude of -300m to 12192m.

Table 2.2.3 Non-Operating environmental specification [Informative]

Condition	Specification	Remark
Non-Operating	-40°C to 85 °C	Apply for outer dimensions of iVDR drive

(3) Shockproof

Need to comply with shockproof test specification described in Annex A.

(4) Insertion / Extraction force of the connector

Table 2.3 Insertion / Extraction force of the connector

Item	Specification
Insertion force	0.48 N/pin (50 gf//pin) Max
Extraction force	0.17 N/pin (17 gf/pin) Min 0.39 N/pin (40 gf/pin) Max

(5) Connector durability (number of cycle)

Table 2.4 Connector durability

Item	Specification
Durability cycles	Plug (iVDR device) : 10,000 cycles or more Receptacle (System side) : 10,000 cycles or more

Note) See Table E.2 on the Annex E for the mechanical performance.

## 2.2 Mechanical dimensions

### 2.2.1 External view

Fig. 2.1 shows an external view of iVDR device EX type.

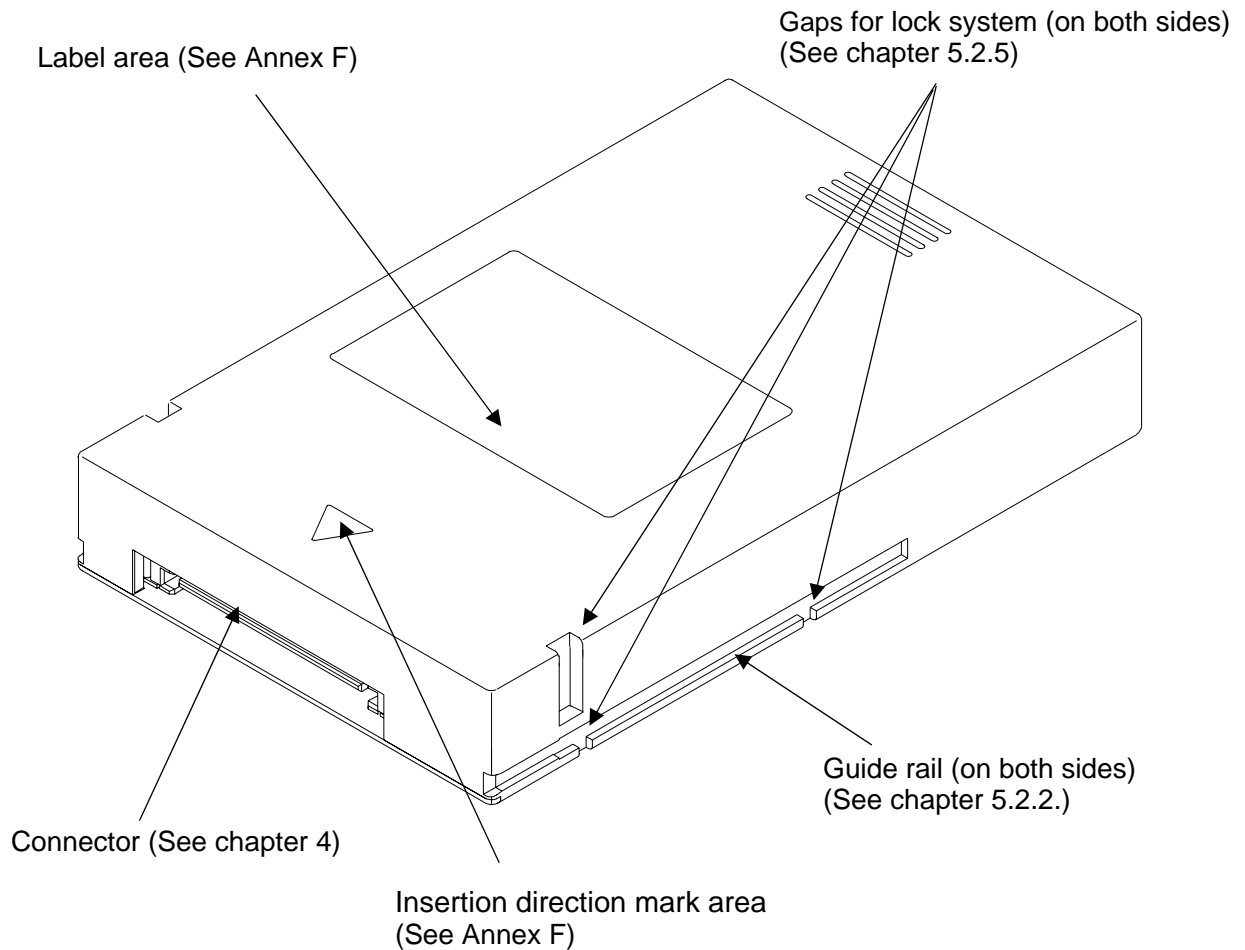

Fig. 2.1 External view of iVDR device EX type

### 2.2.2 Outer dimensions

Fig. 2.2 shows an outline drawing of iVDR device EX type.

See Fig. 5.1 for more details.

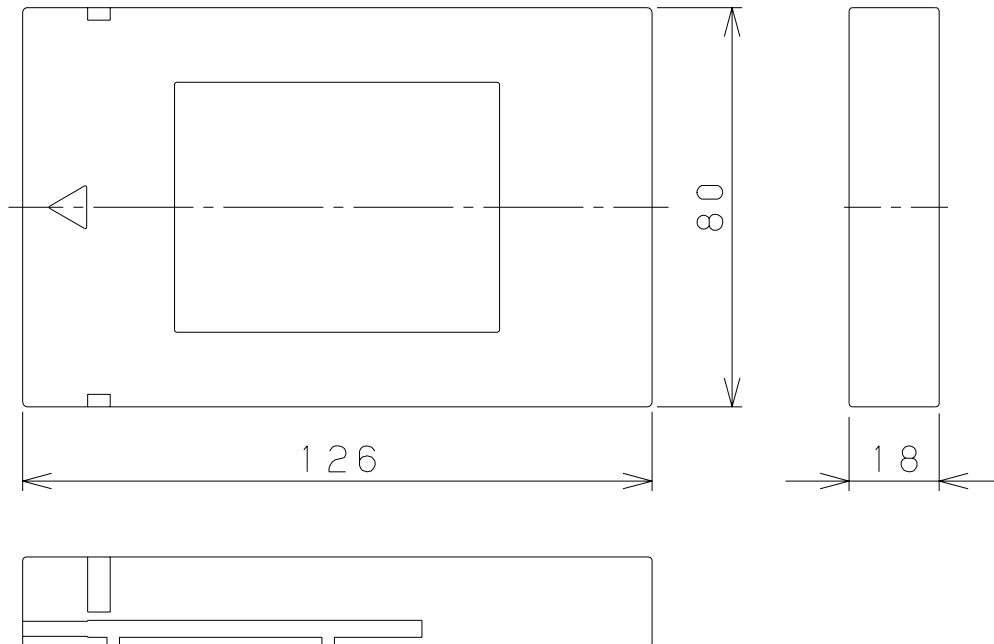

Fig. 2.2 Outline drawing of iVDR device EX type [Unit: mm]

### 2.2.3 Weight

Table 2.5 Weight

Item	Value
Maximum weight	300 g

### **3 Interface specifications**

#### **3.1 Command and interface register descriptions**

Command and interface register of Port A shall follow iVDR-IF-ATA, and Port B shall follow iVDR-IF-USB. Definition of Port A and Port B are described in chapter 4.

#### **3.2 Physical and Electrical characteristics**

Physical and Electrical characteristics are described in chapter 4.

### **4 Connector specifications**

#### **4.1 General specification**

The Plug connector is mounted on iVDR device EX type.  
Fig. 4.1 shows external views of example Plug connector.

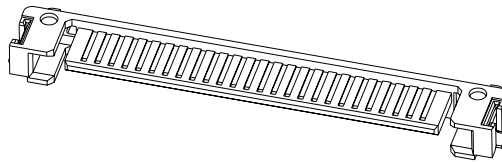

Fig. 4.1 External view of example Plug connector

Note: The Receptacle connector specifications are described in D.1 of Annex D.

##### **4.1.1 Configuration specification**

Fig. 4.2 shows a schematic diagram of the plug connector example showing its structure and dimension.

Terminals and side slots positioned on the lower side allows the shape of the connector to be a symmetric, which provides for a preventive function of incorrect insertion.

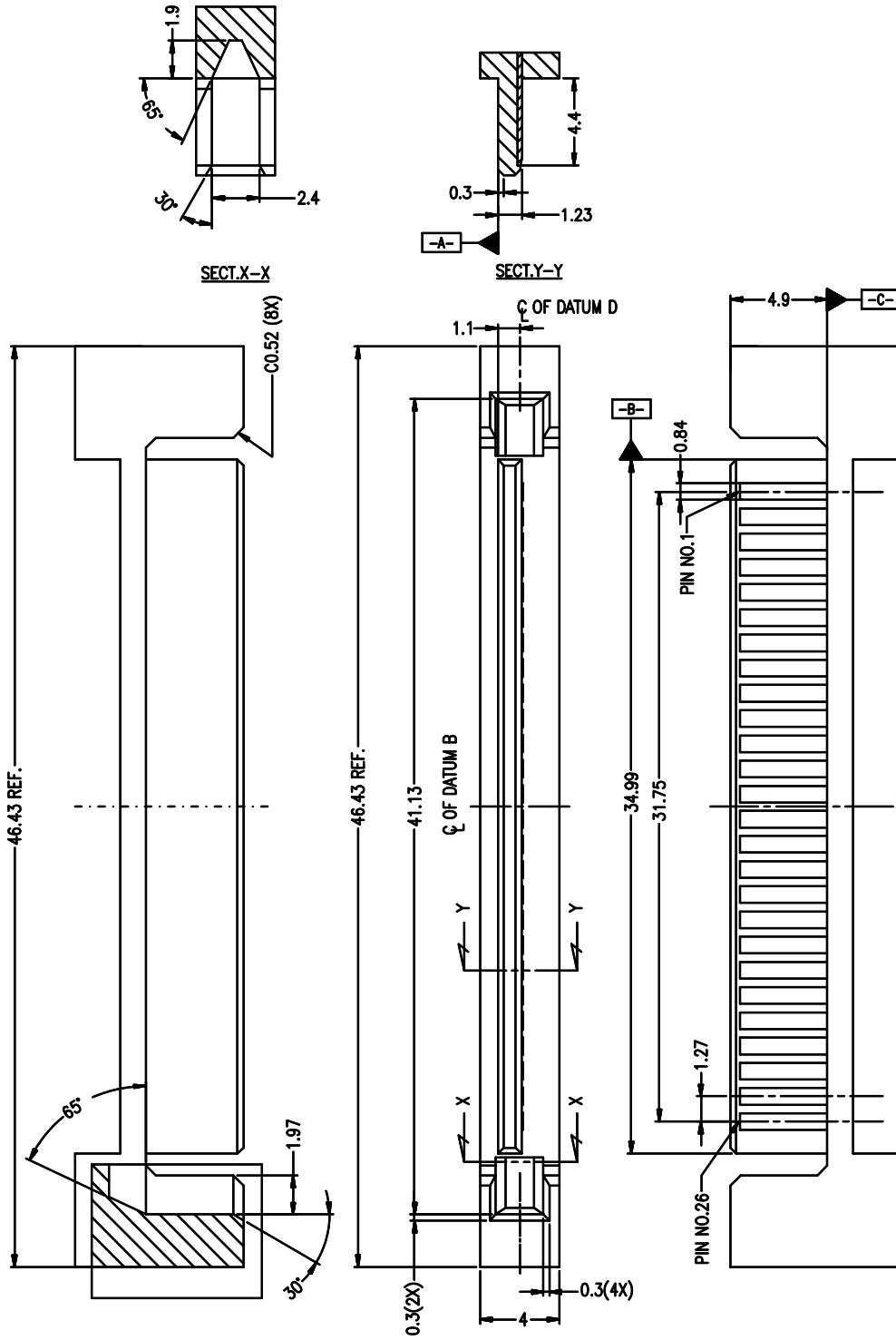

Fig. 4.2 Schematic diagram of plug connector

#### 4.1.2 Contact material and surface plating [Informative]

Table 4.1 shows contact material and surface plating.

Material	Surface plating
Copper alloy	Contact Area : Under plate : Ni Over plate : Au (0.3 $\mu$ m or more) Solder area : Under plate : Ni Over plate : Sn alloy (2.5 $\mu$ m or more) or Au FLASH

#### 4.1.3 Labeling on the connector housing [Informative]

Pin No. (number) can be labeled on the connector housing if necessary.

Note that the name and logo of a manufacturer and the logo of the iVDR device specification can be labeled only if there are no functional problems of the device.

## 4.2 Signal assignment for connector

Fig. 4.3 shows a schematic diagram of the pin configuration, and Table 4.2 shows the pin assignment.

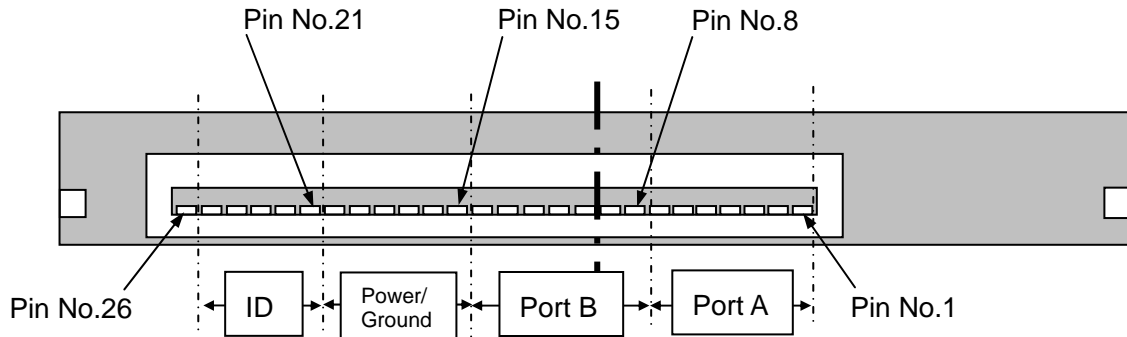

Fig. 4.3 Schematic diagram of the pin configuration of iVDR device

- (1) Port A part  
The Signal assignment and electrical characteristics shall follow Serial-ATA.
- (2) Port B part  
The Signal assignment and electrical characteristics shall follow USB-2.0.
- (3) Power / Ground part  
The setting procedure of this part is shown at Table 4.3.
- (4) ID part  
The setting procedure of this part is shown at Table 4.4.  
The input voltage specification of this part is shown at Table 4.5.

Tale 4.2 Plug Connector Pin Assignment

No.	Name	Type	Description	Port
1	PA-S1	GND	GND	Port A
2	PA-S2	A+	Differential signal	
3	PA-S3	A-	Differential signal	
4	PA-S4	GND	GND	
5	PA-S5	B-	Differential signal	
6	PA-S6	B+	Differential signal	
7	PA-S7	GND	GND	
8	PB-S1-	-	Reserved	Port B
9	PB-S2-	-	Reserved	
10	PB-S3-	-	Reserved	
11	PB-S4	GND	GND	
12	PB-S5	D+	Differential signal	
13	PB-S6	D-	Differential signal	
14	PB-S7	GND	GND	
15	P1	GND	GND	Power/GND
16	P2	GND	GND	
17	P3	GND	GND	
18	P4	PWR	Power	
19	P5	PWR	Power	
20	P6	PWR	Power	
21	ID1	PW-ID 0	Power ID 0	ID
22	ID2	PW-ID 1	Power ID 1	
23	ID3	IF-ID 0	I/F ID 0	
24	ID4	IF-ID 1	I/F ID 1	
25	ID5	IF-ID 2	I/F ID 2	
26	TP1	TP1	Reserved for testing	-

Note) The plug connector pins have same length.

Table 4.3 Power ID Assignment

PW-ID 0	PW-ID 1	Remark
1	1	iVDR device supports 5V.

Note: Power ID sets the voltage value that can be fed into iVDR device.

Table 4.4 I/F ID Assignment

IF-ID 0	IF-ID 1	IF-ID 2	Remark
0	0	0	Port A and Port B Device
0	1	1	Port A only Device
1	0	0	Port B only Device

Note: At iVDR device, logical level shall be designated as follows. Logic “1” (H) = OPEN (Open), Logic “0” (L) = GND (Ground).

By so doing, each ID setting value can be detected, even in condition that the iVDR device is not fed with power.

Note: If the iVDR device is Port A only device, pins of Port B are optional.

Note: If the iVDR device is Port B only device, pins of Port A are optional.

Annex C shows the entire ID assignment possibilities and examples of system detection by ID pin, as a supplementary item [Informative] related to the specification of this iVDR interface.

Table4.5 Input Voltage of ID Part

Item	Specification
Input voltage	+ 6 V Max

## 5 Detailed mechanical specifications

### 5.1 Overall detailed diagram

Figs. 5.1, 5.2 and 5.3 show overall detailed diagram of iVDR device EX type. Unless stated otherwise, tests and measurements made on the iVDR drive to check conformance with this document shall be carried out under the following conditions.

Table 5.1 Testing environment specifications

NO	Item	Specification
1	Temperature	20 °C± 3 °C
2	Relative humidity	50 % ± 20 %
3	Condition before testing	24 h Min

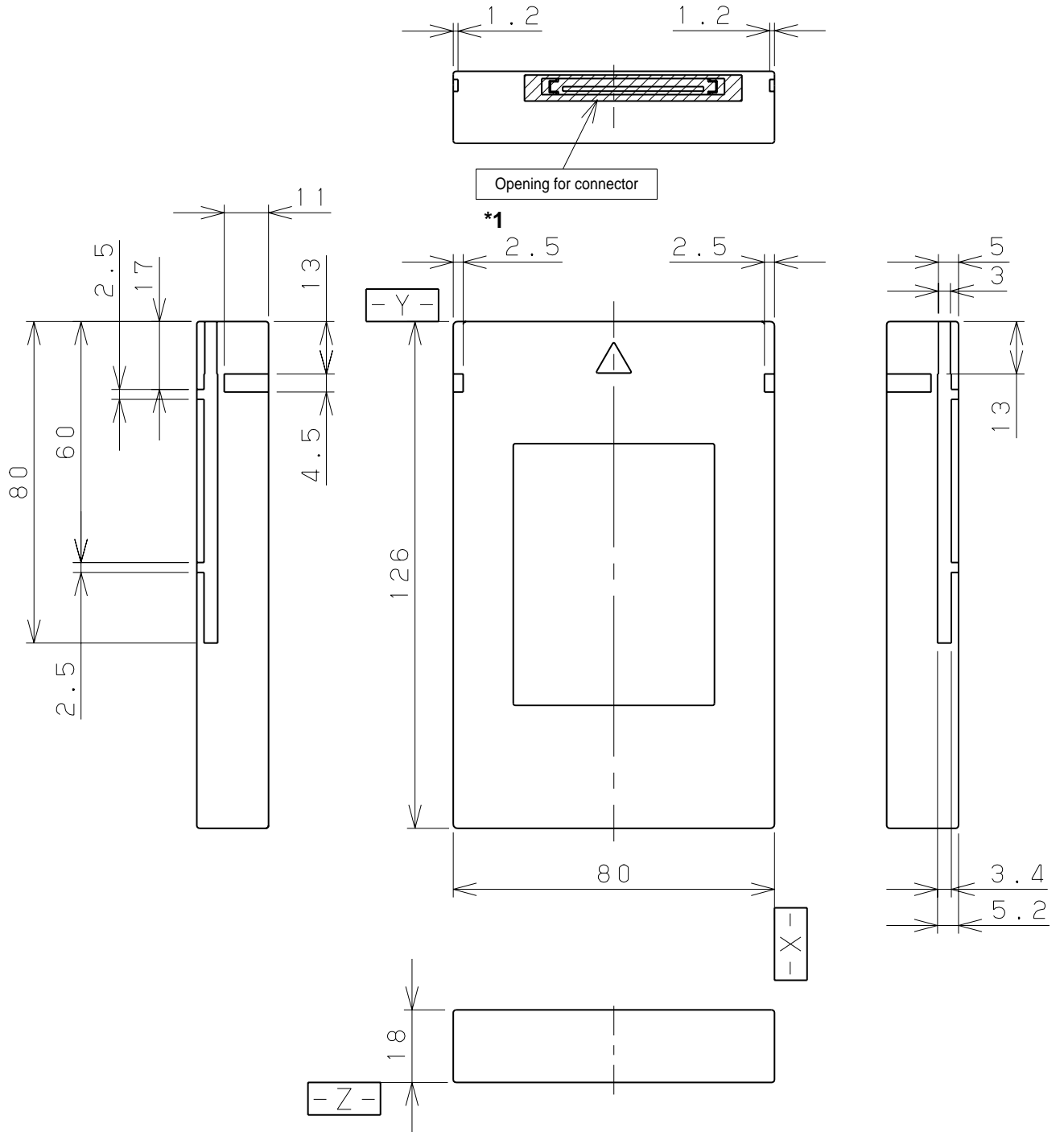
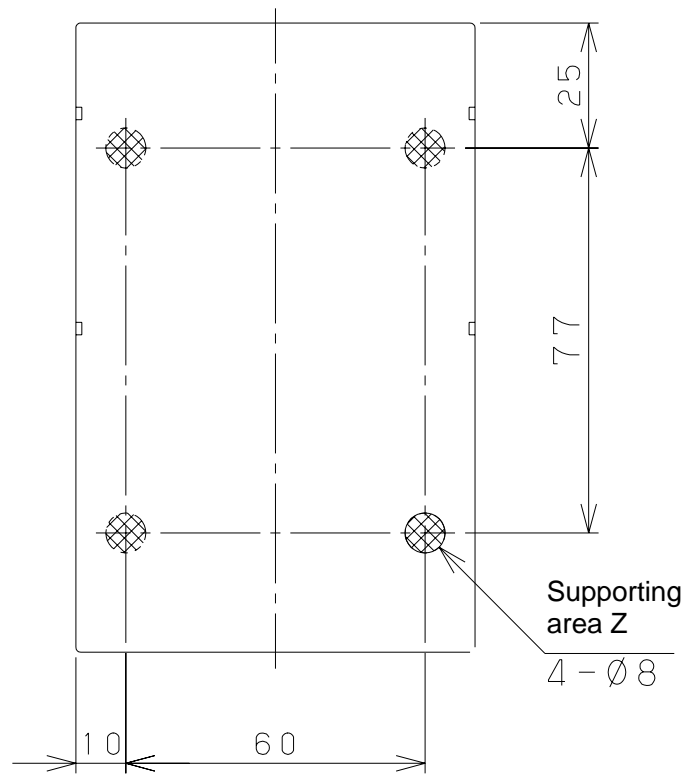

Fig. 5.1 Overall detailed diagram of iVDR device EX type [Unit: mm]



Bottom view

Note) Indicates Supporting area Z with the flatness of 0.15.

Fig.5.2 Supporting area at bottom part of iVDR device EX type [Unit mm]

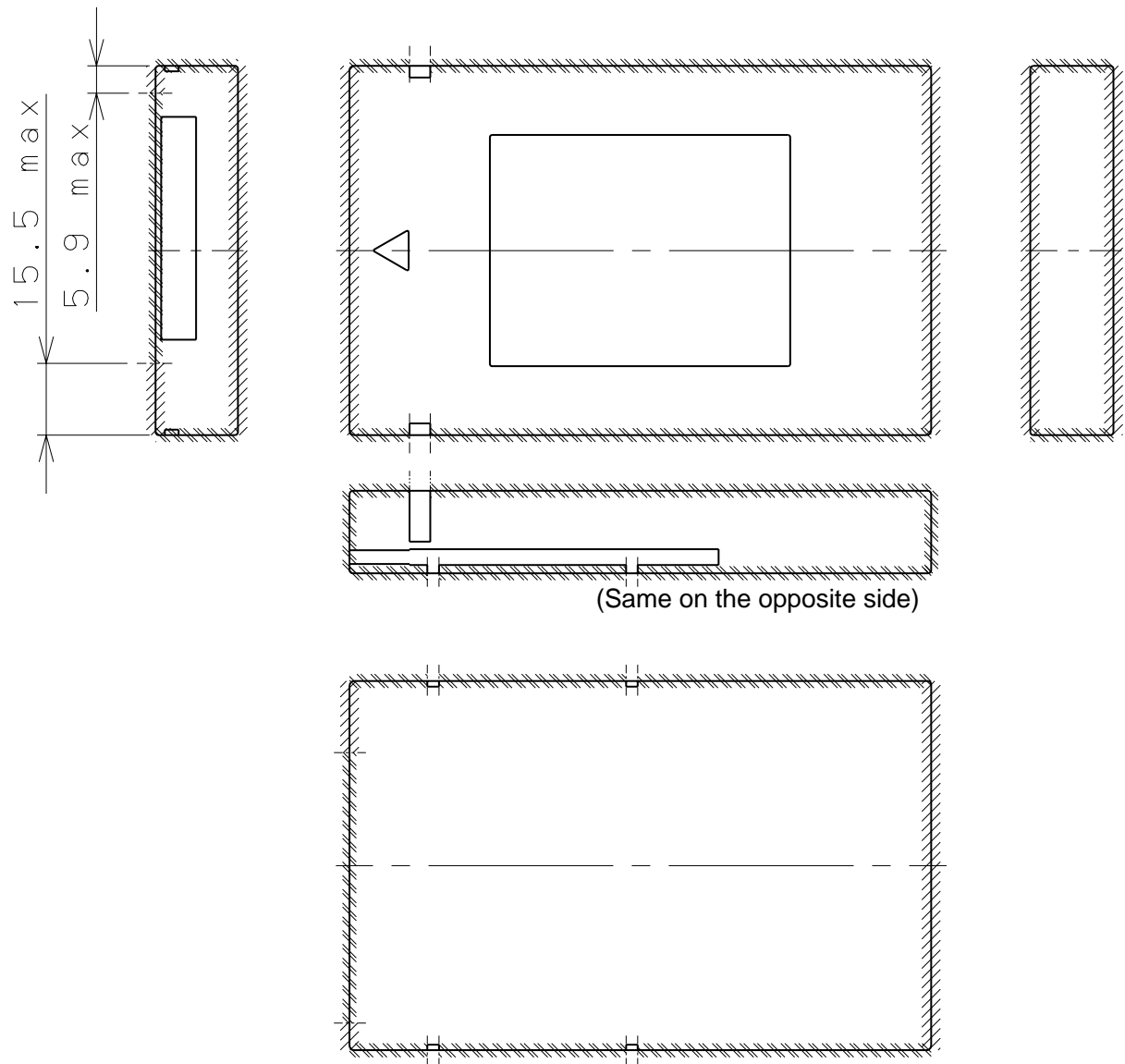



Note) The edge marked with Hatching  can be with rounding shape of R9 max.  
The edge marked with Hatching  can be with rounding shape of R2 max.  
Note) The diagram of example case with rounding edge is shown in Annex H.

Fig.5.3 Rounding edge permitted Section

## **5.2 Mechanical characteristics**

### **5.2.1 Outer dimensions and Datum (X, Y, Z)**

Abbreviation

### **5.2.2 Guide rail**

Abbreviation

### **5.2.3 Eject area**

Abbreviation

### **5.2.4 Clamp area**

Abbreviation

### **5.2.5 Gaps for lock system**

Abbreviation

### 5.2.6 Connector position

Fig. 5.10 shows the position of the plug connector.

For the detailed specification of the connector, see chapter 4 "Connector specifications".

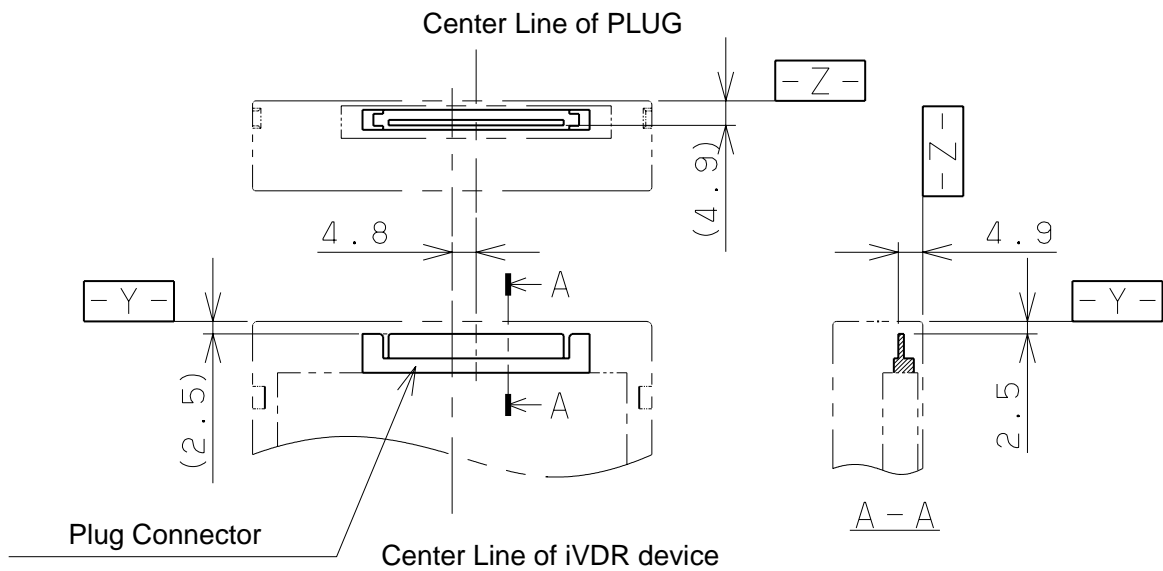

Fig. 5.10 Position of plug connector [Unit: mm]

## Annex A

### **A Specification of the iVDR device shockproof test [Normative]**

This annex describes shockproof test and standards which are applied to the iVDR device.

#### **A.1 Test procedure**

Abbreviation

#### **A.2 Test standard**

Abbreviation

#### **A.3 Shock measurement [informative]**

Abbreviation

#### **A.4 Measurement tool of shockproof test**

Abbreviation

## Annex B

### B Supplementary explanation related to the specification of the iVDR interface [Informative]

#### B.1 Power ID Assignment

Table B.1 summarizes the Power ID assignment possibilities.

Table B.1 Power ID Assignment

PW-ID 0	PW-ID 1	Remark
0	0	Reserved
1	0	Reserved
0	1	iVDR device supports both 5V and 3.3V.
1	1	iVDR device supports 5V.

#### B.2 I/F ID Assignment

Table B.2 summarizes the entire I/F ID assignment possibilities.

Table B.2 I/F ID Assignment

IF-ID 0	IF-ID 1	IF-ID 2	Remark
0	0	0	Port A & Port B Device
0	0	1	Reserved
0	1	0	
0	1	1	Port A only Device
1	0	0	Port B only Device
1	0	1	Reserved
1	1	0	
1	1	1	No Device

#### B.3 An example of system recognition by ID pin

Abbreviation

# Annex C

## C Receptacle Connector specification [Normative]

### C.1 Configuration specification

Fig. C.1 shows a schematic diagram of the receptacle connector example showing its structure and dimension

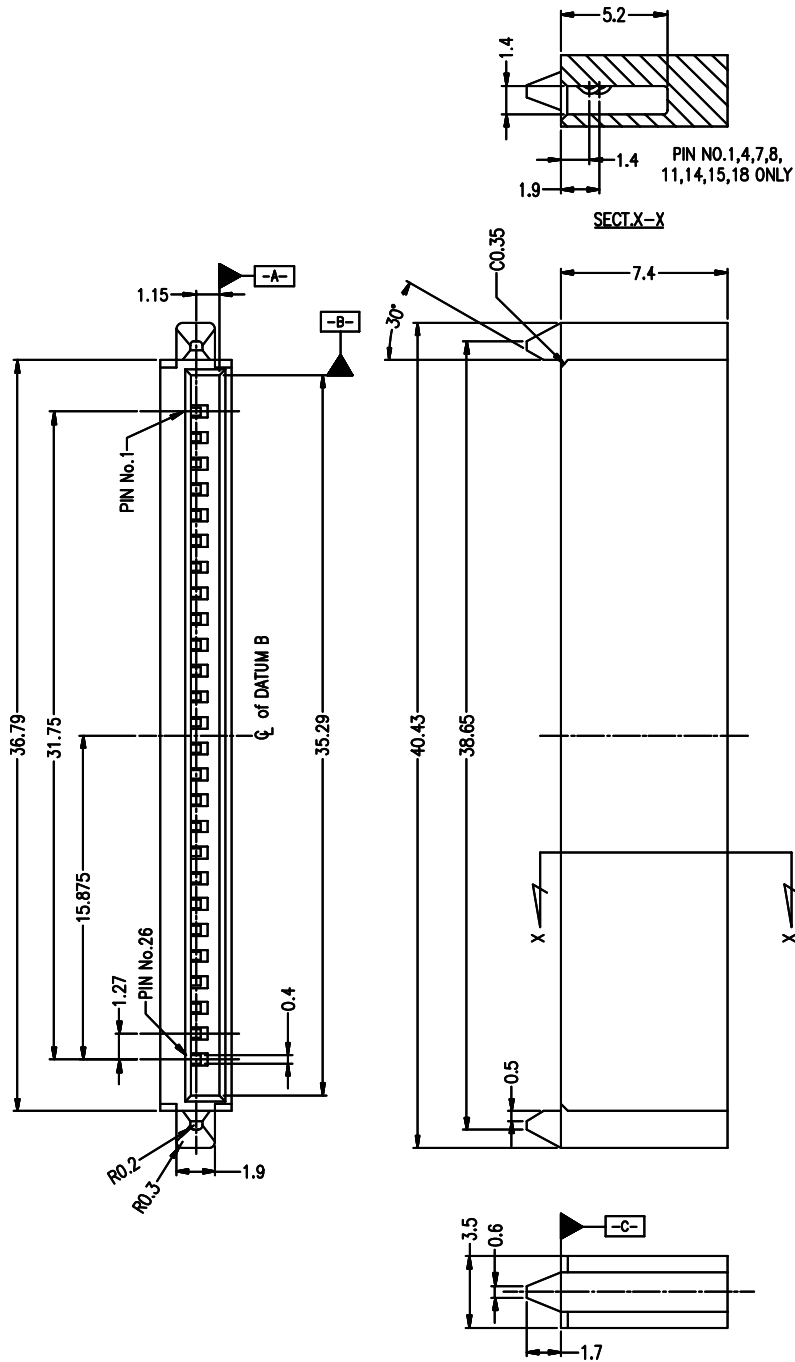

Fig. C.1 Schematic diagram of receptacle connector

## C.2 Contact material and surface plating [Informative]

Table C.1 Material and surface treatment of the terminal

Material	Surface plating
Copper alloy	Contact Area : Under plate : Ni Over plate : Au (0.3μm or more) Solder area : Under plate : Ni Over plate : Sn alloy (2.5μm or more) or Au FLASH

## C.3 Signal assignment for connector

Table C.2 Receptacle Connector Pin Assignment

No.	Name	Type	Description	Pin Length	Port
1	PA-S1	GND	GND	Long	Port A
2	PA-S2	A+	Differential signal	Short	
3	PA-S3	A-	Differential signal	Short	
4	PA-S4	GND	GND	Long	
5	PA-S5	B-	Differential signal	Short	
6	PA-S6	B+	Differential signal	Short	
7	PA-S7	GND	GND	Long	
8	-	-	Reserved	Long	Port B
9	-	-	Reserved	Short	
10	-	-	Reserved	Short	
11	PB-S4	GND	GND	Long	
12	PB-S5	D+	Differential signal	Short	
13	PB-S6	D-	Differential signal	Short	
14	PB-S7	GND	GND	Long	
15	P1	GND	GND	Long	Power/GND
16	P2	GND	GND	Short	
17	P3	GND	GND	Short	
18	P4	PWR	Power	Long	
19	P5	PWR	Power	Short	
20	P6	PWR	Power	Short	
21	ID1	PW-ID 0	Power ID 0	Short	ID
22	ID2	PW-ID 1	Power ID 1	Short	
23	ID3	IF-ID 0	I/F ID 0	Short	
24	ID4	IF-ID 1	I/F ID 1	Short	
25	ID5	IF-ID 2	I/F ID 2	Short	
26	TP1	TP1	Reserved for testing	Short	-

## Annex D

### **D Connecting condition of connector [Informative]**

#### **D.1 Misalignment tolerance on a relative position of the connector**

Abbreviation

#### **D.2 Fully-mated dimension**

Abbreviation

## Annex E

### **E Test specification of connector [Normative]**

This attachment defines environment, test content and specifications of the connectors used for the iVDR device.

#### **E.1 Test content and standard**

Abbreviation

#### **E.2 Test procedure [Informative]**

Abbreviation

## Annex F

### **F Optional area [informative]**

#### **F.1 Insertion direction mark area and label area**

Abbreviation

## Annex G

### **G Capacity of iVDR device [Informative]**

#### **G.1 Value of LBA count of iVDR device**

Abbreviation

## Annex H

### H Example of Case with rounding edge [Informative]

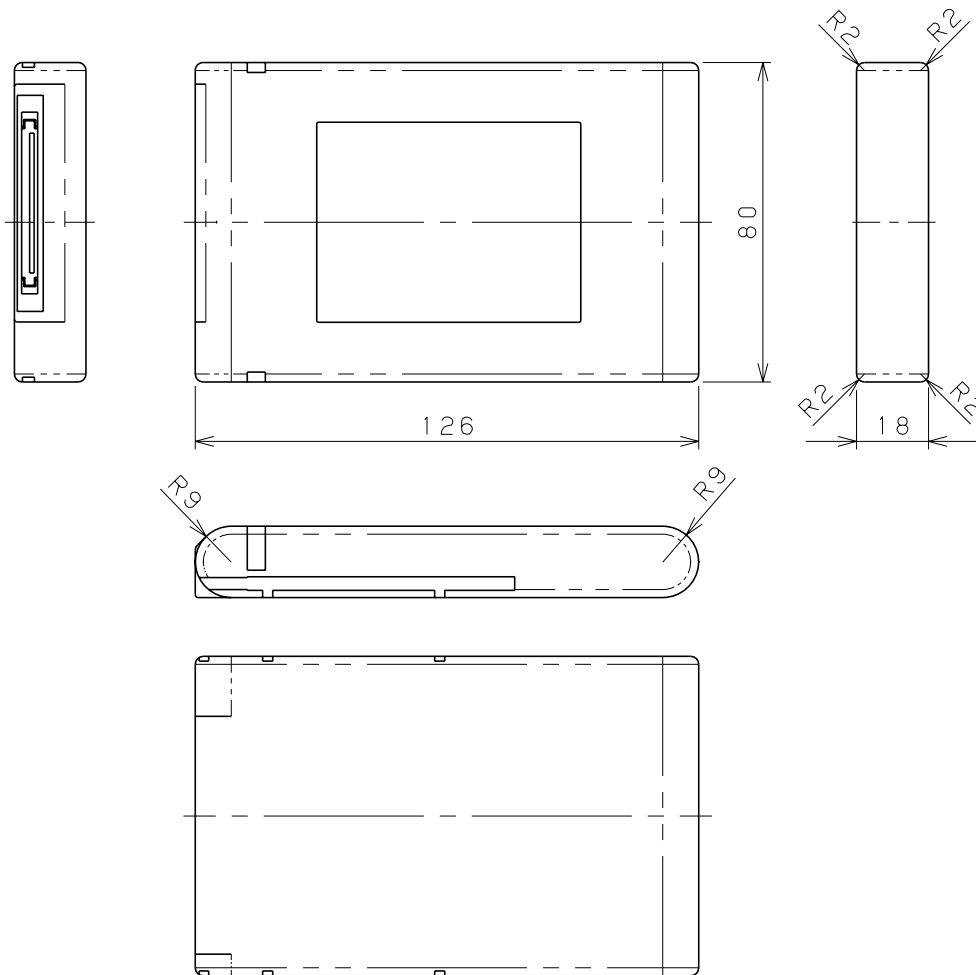

Fig. H.1 Outline drawing of example case with rounding edges.

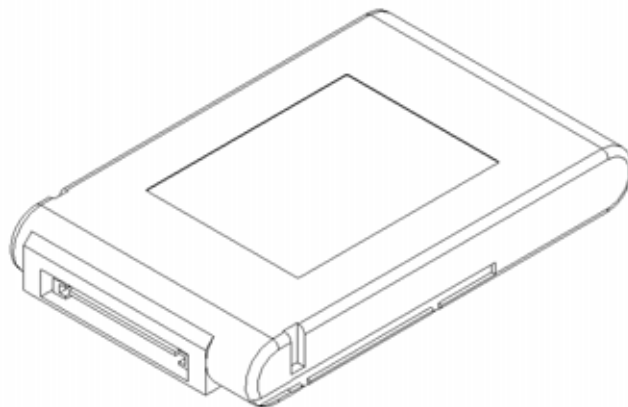

Fig. H.2 External view of example case with rounding edges.