

iVDR
**- Outline of Hardware
Specification -
(Mini type)**

iVDR Consortium

Version 2.11
Jul. 2011

Conditions of publication

This document presents an outline of “iVDR Hard Disk Drive – Hardware Specification – [Mini type] version 2.10, May 2010”.

■ Attention

This document presents only the outline specification. If you manufacture iVDR product, please join “iVDR Consortium” and manufacture it based on the official iVDR Specification.

■ Note

Please refer to the above mentioned standard document for the items indicated as “abbreviation” in sentences.

■ Publisher

iVDR Consortium

■ Inquiry

iVDR Consortium

[<http://www.ivdr.org/>]

iVDR Consortium Secretariat:

Located in I-O Data Device, Inc.

9th FL., North Wing, Akihabara UDX Bldg.,

4-14-1 Sotokanda, Chiyoda-ku, Tokyo, 101-0021, Japan

Phone/Fax: +81-3-6687-1570 E-mail: info@ivdr.org

■ Revision Description

Ver.	Date	Change	Description of the change
1.00	Apr. 2004	Newly created	-
2.00	Aug. 2008	Revised	Revised based on Hardware Specification [Mini type] Version 2.00, 2008
2.01	Sep. 2009	Change the consortium name.	IVDR Hard Disk Drive Consortium → iVDR Consortium
2.10	Oct. 2010	Changed	Change the consortium secretariat location Revised up reference version of Interface Specification
		Added	Maximum weight was defined Add environmental conditions
2.11	Jul. 2011	Added	Attention was added in "Conditions of publication"

Contents

1	General	1
1.1	Scope.....	1
1.2	Reference	2
1.3	New world brought by iVDR [Informative]	3
2	Hardware specifications	4
2.1	Device specifications.....	4
2.2	Mechanical dimensions.....	6
2.2.1	External view	6
2.2.2	Outer dimensions	7
2.2.3	Weight.....	7
3	Interface specifications	8
3.1	Command and interface register descriptions	8
3.2	Physical and Electrical characteristics	8
4	Connector specifications	8
4.1	General specification.....	8
4.1.1	Configuration specification	8
4.1.2	Contact material and surface plating [Informative]	10
4.1.3	Labeling on the connector housing [Informative].....	10
4.2	Signal assignment for connector.....	11
5	Detailed mechanical specifications	14
5.1	Overall detailed diagram	14
5.2	Mechanical characteristics	15
5.2.1	Outer dimensions and Datum (X, Y, Z)	15
5.2.2	Guide rail.....	16
5.2.3	Load area and Eject area	16
5.2.4	Clamp area.....	16
5.2.5	Gaps for lock system.....	16
5.2.6	Connector position	16
A	Specification of the iVDR drive shockproof test [Normative]	17
A.1	Test procedure.....	17
A.2	Test standard.....	17
A.3	Shock measurement result of iVDR standard [Informative].....	17
A.4	Measurement tool of shockproof test	17
B	Supplementary explanation related to the specification of the iVDR interface [Informative]	18
B.1	Power ID Assignment.....	18
B.2	I/F ID Assignment	18
B.3	An example of system recognition by ID pin	18
C	Receptacle Connector specification [Normative]	19
C.1	Configuration specification	19

C.2	Contact material and surface plating [Informative]	20
C.3	Signal assignment for connector	20
D	Connecting condition of connector [Informative].....	21
D.1	Misalignment tolerance on a relative position of the connector	21
D.2	Fully-mated dimension	21
E	Test specification of connector [Normative].....	21
E.1	Test content and standard	21
E.2	Test procedure [Informative]	21
F	Optional area [Informative]	21
F.1	Insertion direction mark area and label area	21
G	Capacity of iVDR drive [Informative].....	21
G.1	Value of LBA count of iVDR drive	21

1 General

1.1 Scope

The iVDR drive is a portable data storage equipped with an interface.
An example iVDR drive is shown in Fig. 1.1.



Fig. 1.1 External view of example iVDR drive

This specification describes requirements for the iVDR drive, including the external shape and durability of the case and connectors.

1.2 Reference

- 1) iVDR 2010
Interface specification (ATA) 2.10 (iVDR-IF)
- 2) Serial ATA Interface Organization
Serial ATA Revision 2.6, February 15, 2007 (Serial-ATA)
- 3) MIL-STD-810C
Test Method Standard for Environmental Engineering Considerations and Laboratory Tests
- 4) ANSI/EIA-364-20B-1999 (EIA364-20B)
Withstanding Voltage Test Procedure for Electrical Connectors, Sockets and Coaxial Contacts
- 5) ANSI/EIA-364-21C-2000 (EIA364-21C)
Insulation Resistance Test Procedure for Electrical Connectors, Sockets, and Coaxial Contacts
- 6) ANSI/EIA-364-23B-2000 (EIA364-23B)
Low Level Contact Resistance Test Procedure for Electrical Connectors and Sockets
- 7) MIL-STD-202
Test Methods for Electronic and Electrical Component Parts
- 8) MIL-F-14256E
FLUX, SOLDERING, LIQUID (ROSIN BASE)
- 9) QQ-S-571E
Solder; Tin Alloy, Tin-Lead Alloy, and Lead Alloy.
- 10) ANSI NCITS 340 2002
Information Technology – AT Attachment with Packet Interface – 6 (ATA-6)
- 11) ANSI NCITS 340 2005
Information Technology – AT Attachment with Packet Interface – 7 Volume 1 (ATA-7/V1)
- 12) The International Disk Drive Equipment and Materials Association
LBA1-02: LBA Standard [Approved Standards of LBA Standards] (IDEMA/LBA1-02)

1.3 New world brought by iVDR [Informative]

Interface and application format standardization of high-capacity and high-speed removable medium can provide a media link between electronic devices.

Fig.1.2 shows a conceptual illustration of the media link.



Fig. 1.2 Media link

2 Hardware specifications

2.1 Device specifications

(1) Power specifications

Table 2.1.1 Supply voltage specifications

NO	Item	Specification	
1	Power	+5V±5 %	+3.3V±5% (optional)
2	Ripple Noise	100 mVp-p Max (Frequency: DC to 1MHz)	

Table 2.1.2 Supply current specifications

Item	Specification
	+5V input / +3.3V input
Incident peak current	2 A Max
Maximum duration time of peak current	3 sec Max

(2) Environment specifications

Table 2.2.1 Operating environmental specifications

NO	Item	Specification
1	Temperature	5 °C to 50 °C
2	Relative humidity	8 % to 90 %
3	Wet bulb temperature	29.4 °C Max
4	Temperature gradient	20 °C/h Max
5	Atmospheric pressure	714 hPa to 1050 hPa
6	Vibration	9.8 m/sec ² Max. at 5-500Hz 1octave / minute of swept sine wave

Note) Atmospheric pressure equivalents to the altitude of -300m to 3048m.

Table 2.2.2 Non-operating (Storage) environmental specifications

NO	Item	Specification
1	Temperature	-40 °C to 65 °C
2	Relative humidity	5 % to 95 %
3	Wet bulb temperature	40 °C Max
4	Temperature gradient	20 °C/h Max
5	Atmospheric pressure	282 hPa to 1050 hPa

Note) Atmospheric pressure equivalents to the altitude of -300m to 12192m.

Table 2.2.3 Environmental specification [Informative]

Condition	Specification	Remark
Non-Operating	-40-85 deg. Celsius	Apply for outer dimensions of iVDR drive

(3) Shockproof

Need to comply with shockproof test specification described in Annex B.

(4) Insertion / Extraction force of the connector

Table 2.3 Insertion / Extraction force of the connector

Item	Specification
Insertion force	0.48 N/pin (50 gf//pin) Max
Extraction force	0.17 N/pin (17 gf/pin) Min 0.39 N/pin (40 gf/pin) Max

(5) Connector durability (number of cycle)

Table 2.4 Connector durability

Item	Specification
Durability cycles	Plug (iVDR drive) : 10,000 cycles or more
	Receptacle (System side) : 10,000 cycles or more

Note) See Table E.2 on the Annex F for the mechanical performance.

2.2 Mechanical dimensions

2.2.1 External view

Fig. 2.1 shows an external view of iVDR drive Mini type.

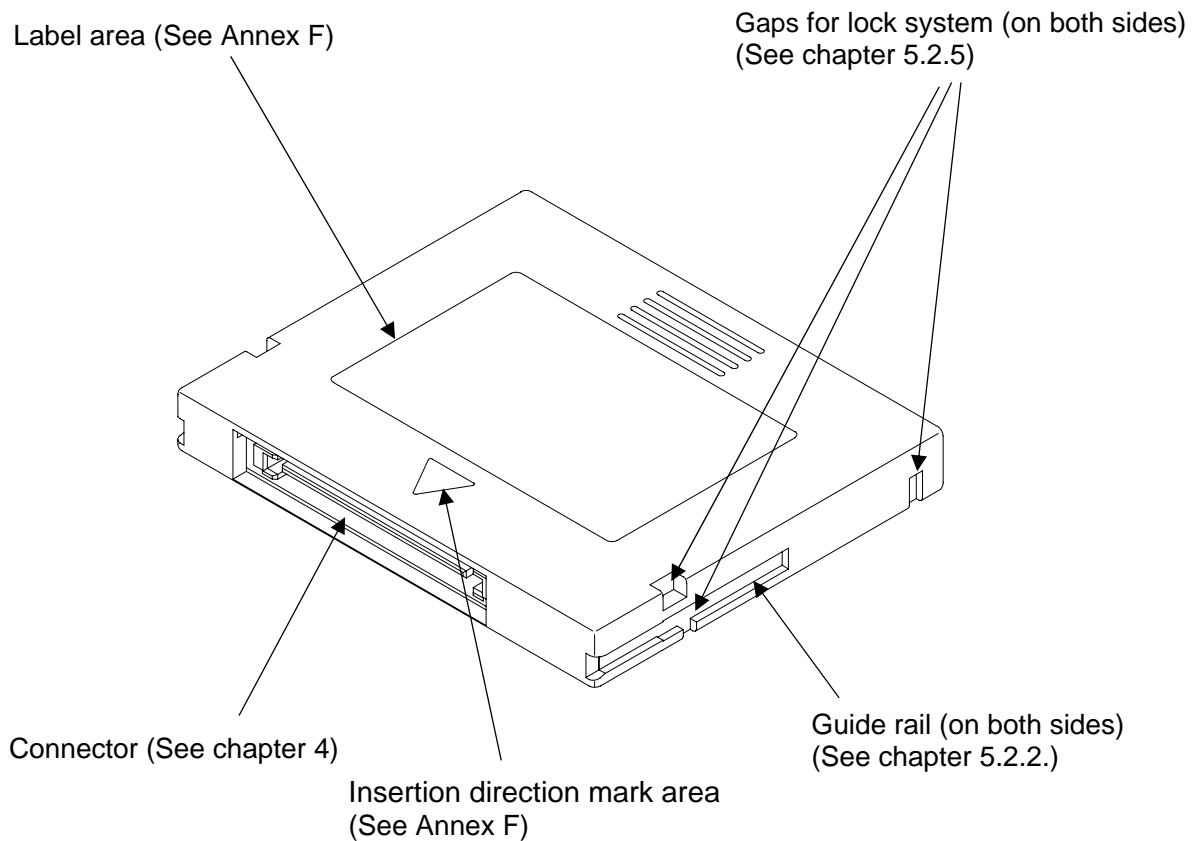

Fig. 2.1 External view of iVDR drive Mini type

2.2.2 Outer dimensions

Fig. 2.3 shows an outline drawing of iVDR drive Mini type.

See Fig. 5.1 for more details.

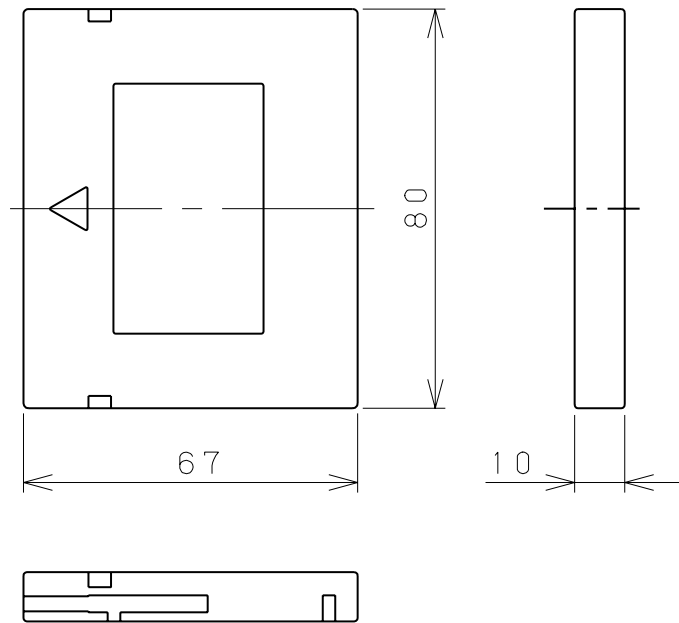

Fig. 2.2 Outline drawing of iVDR drive Mini type [Unit: mm]

2.2.3 Weight

Table 2.5 Weight

Item	Value
Maximum weight	200g

3 Interface specifications

3.1 Command and interface register descriptions

Command and interface register shall follow IVDR-IF.

3.2 Physical and Electrical characteristics

Physical and Electrical characteristics are described in chapter 4.

4 Connector specifications

4.1 General specification

The plug connector mounted on iVDR drive Mini type.

Fig. 4.1 shows external views of the example connectors.

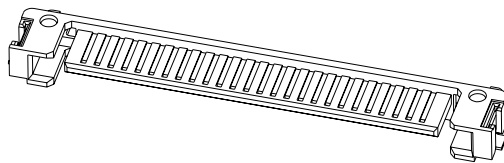

Fig. 4.1 External view of example Plug connectors

Note: The Receptacle connector specifications are described in D.1 of Annex D.

4.1.1 Configuration specification

Fig. 4.2 shows a schematic diagram of the plug connector example showing its structure and dimension.

Terminals and side slots positioned on the lower side allows the shapes of the connectors to be a symmetric, which provides for a preventive function of incorrect insertion.

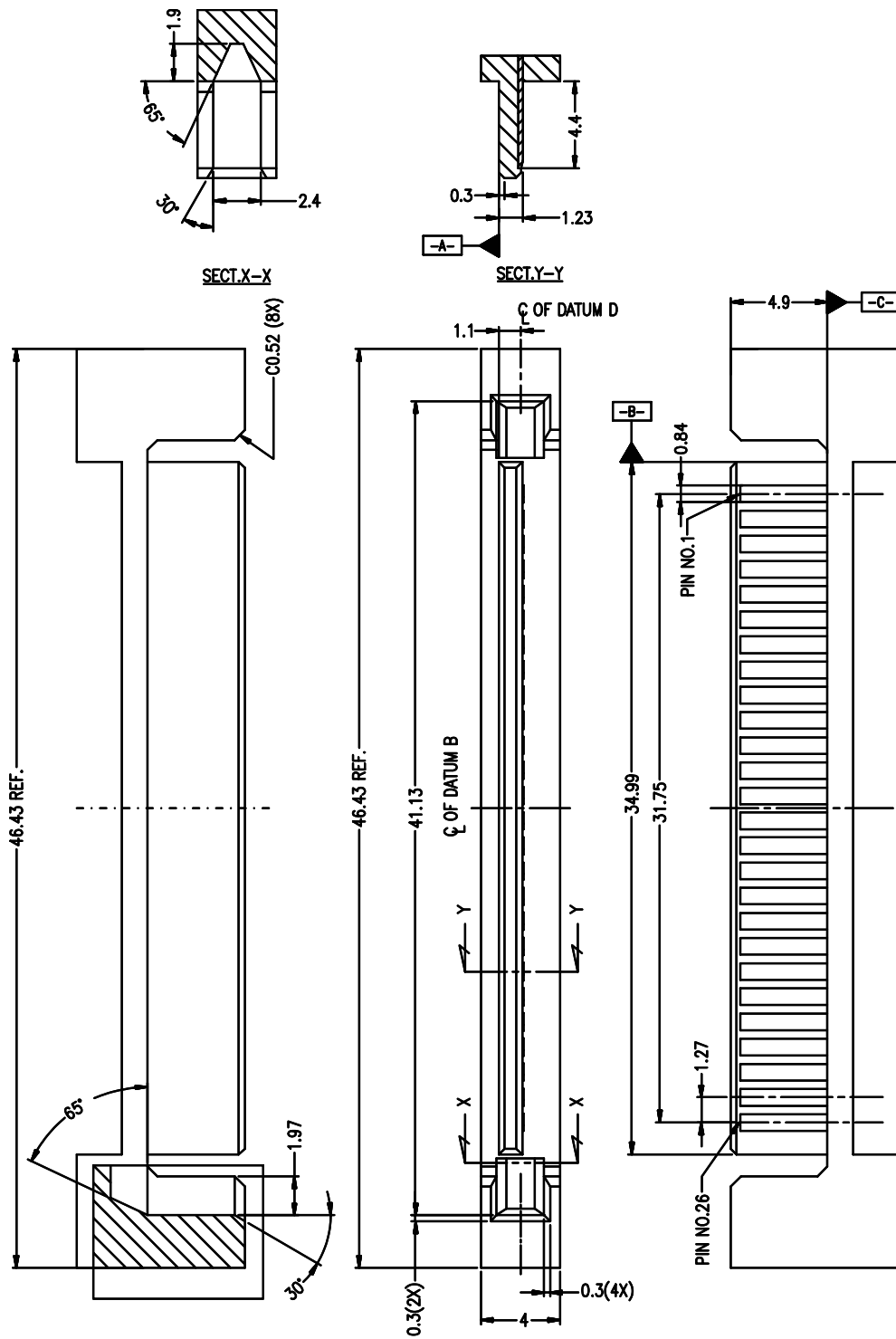

Fig. 4.2 Schematic diagram of plug connector

4.1.2 Contact material and surface plating [Informative]

Table 4.1 shows contact material and surface plating.

Material	Surface plating
Copper alloy	Contact Area : Under plate : Ni Over plate : Au (0.3 μ m or more) Solder area : Under plate : Ni Over plate : Sn alloy (2.5 μ m or more) or Au FLASH

4.1.3 Labeling on the connector housing [Informative]

Pin No. can be labeled on the connector housing if necessary.

Note that the name and logo of a manufacturer and the logo of the iVDR drive specification can be labeled only if there are no functional problems of the device.

4.2 Signal assignment for connector

Fig. 4.3 shows a schematic diagram of the pin configuration, and Table 4.2 shows the pin assignment.

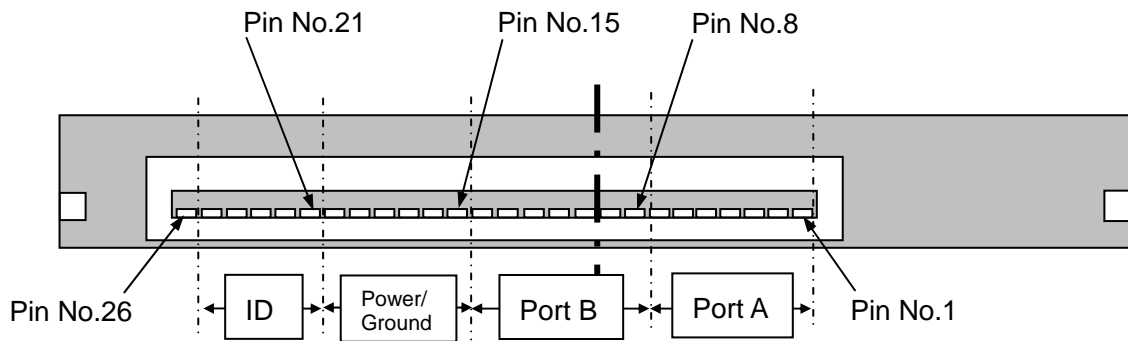

Fig. 4.3 Schematic diagram of the pin configuration of iVDR drive

- (1) Port A part
The Signal assignment and electrical characteristics shall follow Serial-ATA.
- (2) Port B part
This port is not used. Contact pin can be removed.
- (3) Power / Ground part
The setting procedure of this part is shown at Table 4.3.
- (4) ID part
The setting procedure of this part is shown at Table 4.4.
The input voltage specification of this part is shown at Table 4.5.

Table 4.2 Connector Pin Assignment

No.	Name	Type	Description	Port
1	PA-S1	GND	GND	Port A
2	PA-S2	A+	Differential signal	
3	PA-S3	A-	Differential signal	
4	PA-S4	GND	GND	
5	PA-S5	B-	Differential signal	
6	PA-S6	B+	Differential signal	
7	PA-S7	GND	GND	
8	-	-	Reserved	Port B
9	-	-	Reserved	
10	-	-	Reserved	
11	-	-	Reserved	
12	-	-	Reserved	
13	-	-	Reserved	
14	-	-	Reserved	
15	P1	GND	GND	Power/GND
16	P2	GND	GND	
17	P3	GND	GND	
18	P4	PWR	Power	
19	P5	PWR	Power	
20	P6	PWR	Power	
21	ID1	PW-ID 0	Power ID 0	ID
22	ID2	PW-ID 1	Power ID 1	
23	ID3	IF-ID 0	I/F ID 0	
24	ID4	IF-ID 1	I/F ID 1	
25	ID5	IF-ID 2	I/F ID 2	
26	TP1	TP1	Reserved for testing	-

Note) The plug connector pins have same length.

Table 4.3 Power ID Assignment

PW-ID 0	PW-ID 1	Remark
0	1	iVDR drive supports both 5V and 3.3V.
1	1	iVDR drive supports 5V.

Note: Power ID sets the voltage value that can be fed into iVDR drive.

Table 4.4 I/F ID Assignment

IF-ID 0	IF-ID 1	IF-ID 2	Remark
0	1	1	Port A only Device

Note: At iVDR drive, logical level shall be designated as follows. Logic “1” (H) = OPEN (Open), Logic “0” (L) = GND (Ground).

By so doing, each ID setting value can be detected, even in condition that the iVDR drive is not fed with power.

Annex C shows the entire ID assignment possibilities and examples of system detection by ID pin, as a supplementary item [Informative] related to the specification of this iVDR interface.

Table4.5 Input Voltage of ID Part

Item	Specification
Input voltage	6 V Max

5 Detailed mechanical specifications

5.1 Overall detailed diagram

Figs.5.1 and 5.2 show overall detailed diagram of iVDR drive. Unless stated otherwise, tests and measurements made on the iVDR drive to check conformance with this document shall be carried out under the following conditions.

Table 5.1 Testing environment specifications

NO	Item	Specification
1	Temperature	20 °C± 3 °C
2	Relative humidity	50 % ± 20 %
3	Condition before testing	24 h Min

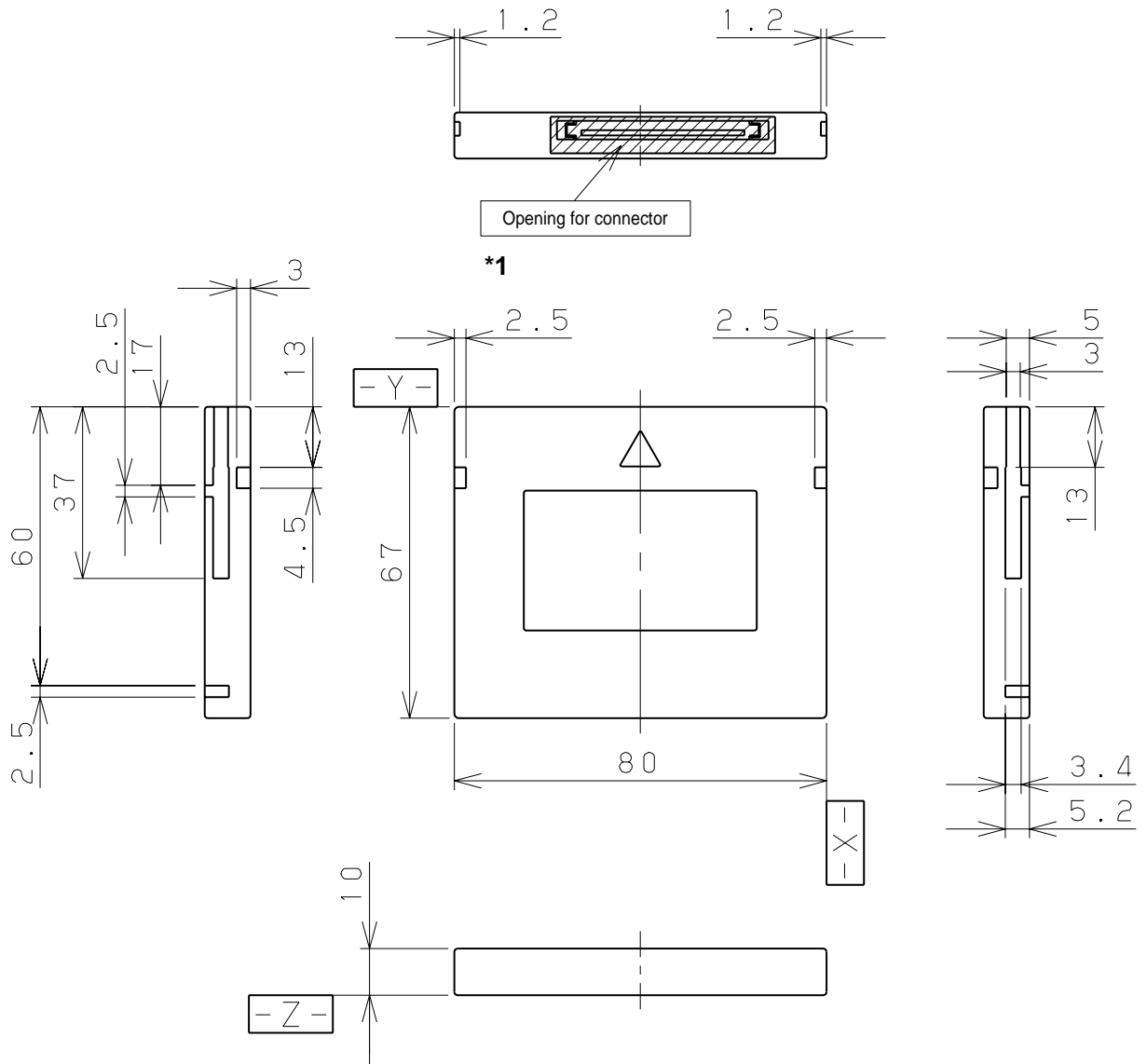

Note)*1. See Fig. 5.2 in section 5.2.7 for detailed position of connector

Fig. 5.1 Overall detailed diagram of iVDR drive Mini type [Unit: mm]

5.2 Mechanical characteristics

5.2.1 Outer dimensions and Datum (X, Y, Z)

Abbreviation

5.2.2 Guide rail

Abbreviation

5.2.3 Load area and Eject area

Abbreviation

5.2.4 Clamp area

Abbreviation

5.2.5 Gaps for lock system

Abbreviation

5.2.6 Connector position

Fig. 5.2 shows the position of the plug connector.

For the detailed specification of the connector, see chapter 4 "Connector specifications".

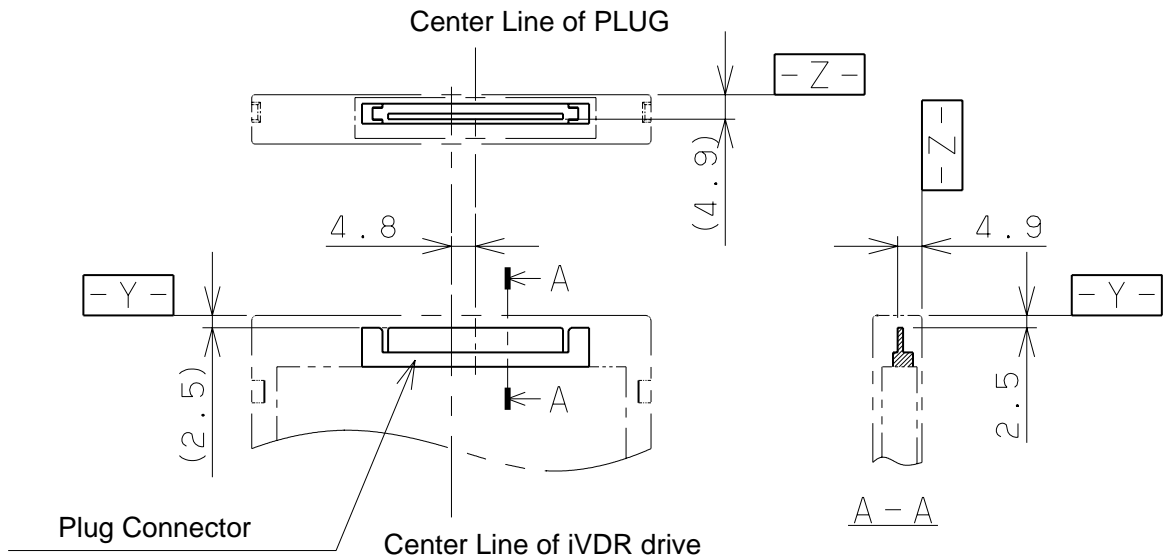

Fig. 5.2 Position of plug connector [Unit: mm]

Annex A

Annex A

A Specification of the iVDR drive shockproof test [Normative]

This annex describes shockproof test and standards which are applied to the iVDR drive.

A.1 Test procedure

Abbreviation

A.2 Test standard

Abbreviation

A.3 Shock measurement result of iVDR standard [Informative]

Abbreviation

A.4 Measurement tool of shockproof test

Abbreviation

Annex B

B Supplementary explanation related to the specification of the iVDR interface [Informative]

B.1 Power ID Assignment

Table B.1 summarizes the Power ID assignment possibilities.

Table B.1 Power ID Assignment

PW-ID 0	PW-ID 1	Remark
0	0	Reserved
1	0	Reserved
0	1	iVDR drive supports both 5V and 3.3V.
1	1	iVDR drive supports 5V.

B.2 I/F ID Assignment

Table B.2 summarizes the entire I/F ID assignment possibilities.

Table B.2 I/F ID Assignment

IF-ID 0	IF-ID 1	IF-ID 2	Remark
0	0	0	Reserved
0	0	1	
0	1	0	Reserved
0	1	1	Port A only Device
1	0	0	Port B only Device
1	0	1	
1	1	0	Reserved
1	1	1	No Device

B.3 An example of system recognition by ID pin

Abbreviation

Annex C

C Receptacle Connector specification [Normative]

C.1 Configuration specification

Fig C.1 shows a schematic diagram of the receptacle connector example showing its structure and dimension

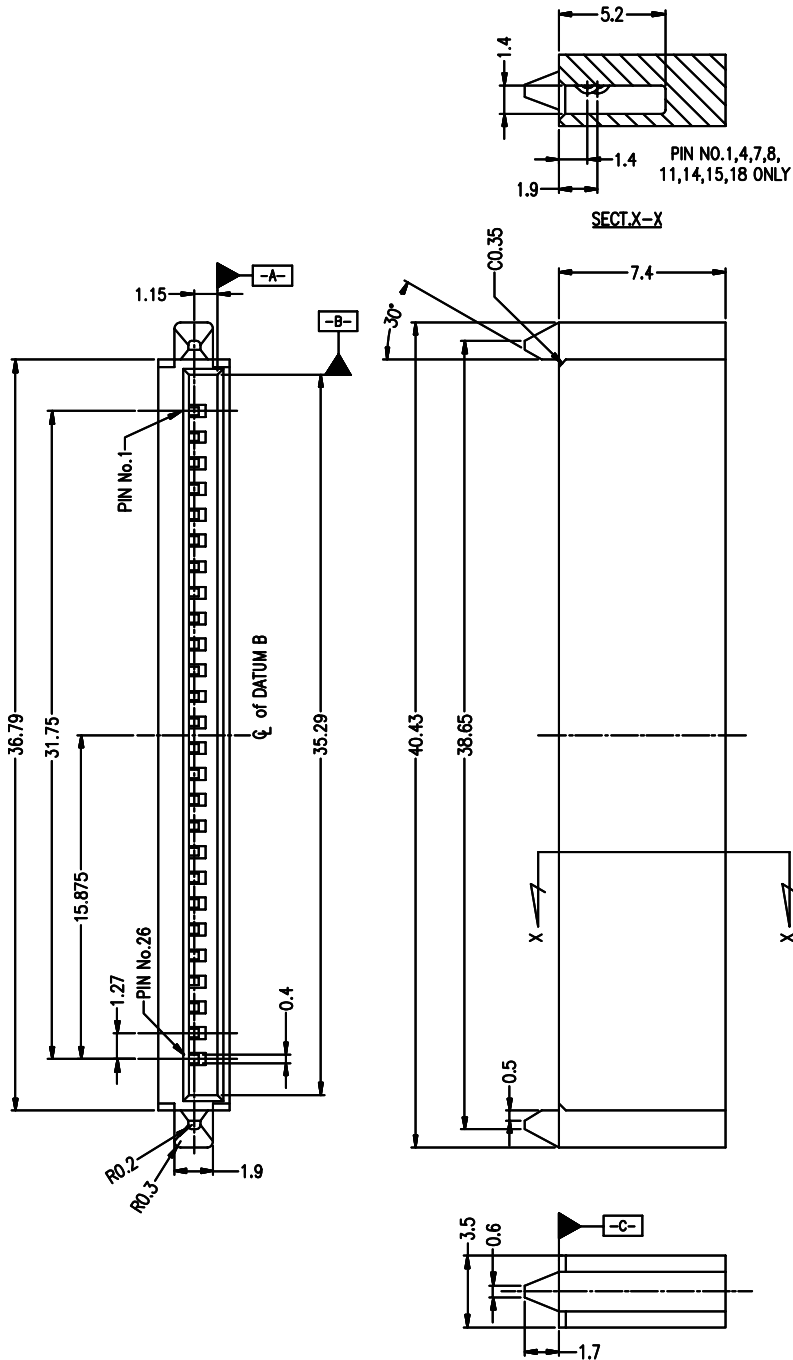

Fig C.1 Schematic diagram of receptacle connector

C.2 Contact material and surface plating [Informative]

Table C.1 Material and surface treatment of the terminal

Material	Surface plating
Copper alloy	Contact Area : Under plate : Ni Over plate : Au (0.3μm or more) Solder area : Under plate : Ni Over plate : Sn alloy (2.5μm or more) or Au FLASH

C.3 Signal assignment for connector

Table C.2 Receptacle Connector Pin Assignment

No.	Name	Type	Description	Pin Length	Port
1	PA-S1	GND	GND	Long	Port A
2	PA-S2	A+	Differential signal	Short	
3	PA-S3	A-	Differential signal	Short	
4	PA-S4	GND	GND	Long	
5	PA-S5	B-	Differential signal	Short	
6	PA-S6	B+	Differential signal	Short	
7	PA-S7	GND	GND	Long	
8	-	-	Reserved	Long	Port B
9	-	-	Reserved	Short	
10	-	-	Reserved	Short	
11	-	-	Reserved	Long	
12	-	-	Reserved	Short	
13	-	-	Reserved	Short	
14	-	-	Reserved	Long	
15	P1	GND	GND	Long	Power/GND
16	P2	GND	GND	Short	
17	P3	GND	GND	Short	
18	P4	PWR	Power	Long	
19	P5	PWR	Power	Short	
20	P6	PWR	Power	Short	
21	ID1	PW-ID 0	Power ID 0	Short	ID
22	ID2	PW-ID 1	Power ID 1	Short	
23	ID3	IF-ID 0	I/F ID 0	Short	
24	ID4	IF-ID 1	I/F ID 1	Short	
25	ID5	IF-ID 2	I/F ID 2	Short	
26	TP1	TP1	Reserved for testing	Short	-

Annex D

D Connecting condition of connector [Informative]

D.1 Misalignment tolerance on a relative position of the connector

Abbreviation

D.2 Fully-mated dimension

Abbreviation

Annex E

E Test specification of connector [Normative]

This attachment defines environment, test content and specifications of the connectors used for the iVDR drive.

E.1 Test content and standard

Abbreviation

E.2 Test procedure [Informative]

Abbreviation

Annex F

F Optional area [Informative]

F.1 Insertion direction mark area and label area

Abbreviation

Annex G

G Capacity of iVDR drive [Informative]

G.1 Value of LBA count of iVDR drive

Abbreviation